

Grade			✓
	A	B	C
0-50	±0.05	±0.10	±0.15
>50-100	±0.10	±0.15	±0.20
>100-150	±0.15	±0.20	±0.50
>150-200	±0.20	±0.30	±0.80
>200-300	±0.25	±0.50	±1.20
>300-500	±0.30	±0.80	±2.0
>500以上	±0.50	±1.20	±3.0

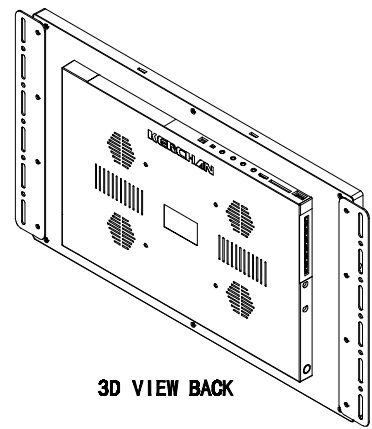
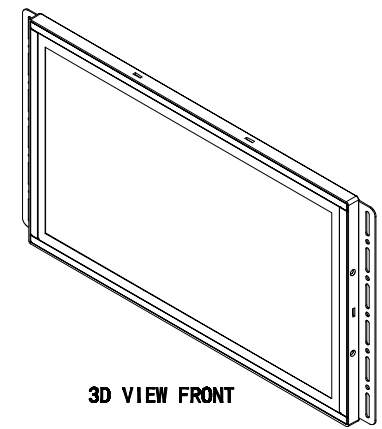
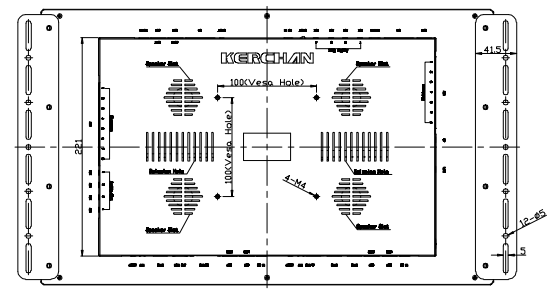
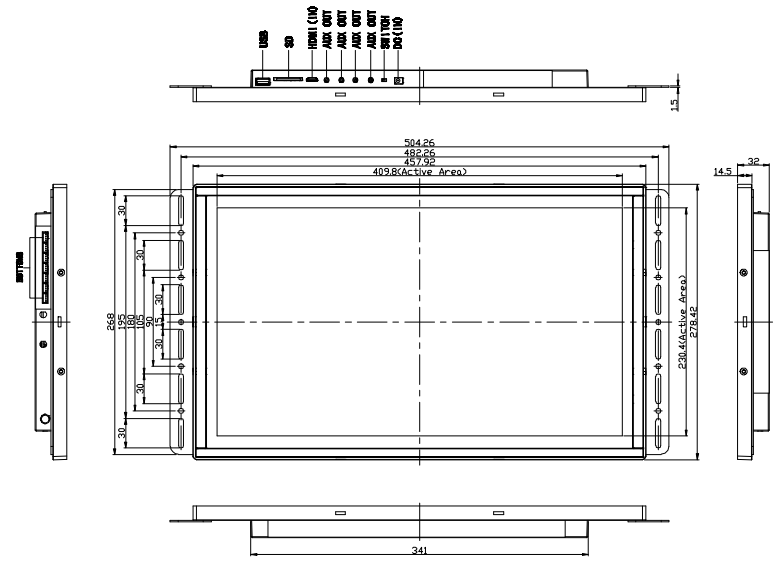

NOTE:
 1、 This product is 18.5 inch advertising machine;
 2、 The shell material of the product is plastic.

KERCHAN
 Professional Innovation
 Kerchan Technology Group Limited

版本号 Rev	单位 Unit	比例 Scale	图号 Drawing No.
A/0	MM	1:1	SAD1850KH-00
第 1 页 共 1 页 Sheet 1 of 1			物料编码 Material No.
			名称 Name:
			18.5 inch advertisting product drawing (YF-V56)

更改说明及标注 Description	ECN号 ECN No.	签名 Signed	日期 Date	版本号 Rev	单位 Unit	比例 Scale	图号 Drawing No.
设计 Designed By	90E		20200219	第 1 页 共 1 页 Sheet 1 of 1	MM	1:1	SAD1850KH-00
审核 Checked By							物料编码 Material No.
批准 Approved By							名称 Name:

图形识别符号 Graphic identification symbols		
--	--	--